

Copying of this document and giving it to others and the use or communication of the contents thereof, are forbidden without express authority. Offenders are liable to the payment of damages. All rights are reserved in the event of the grant of a patent or the registration of the utility model or design.

Crimpzange komplett inkl. Kontaktaufnahme für 1,6 mm Kontakte und Prüfstiftset für 1,6 mm Kontakte
 crimping tool complete incl. contact locator for 1,6 mm contacts and calibration pin set for 1,6 mm contacts

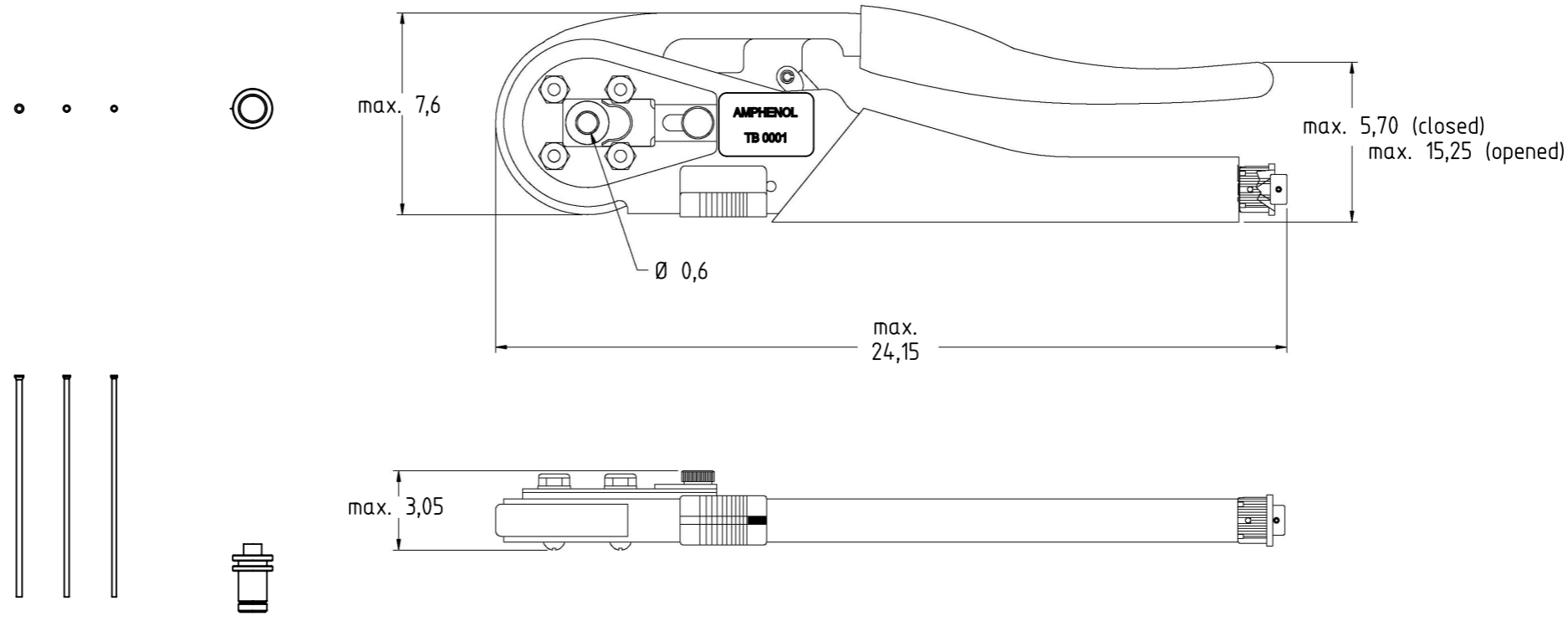

Alle technischen Daten wurden unter Laborbedingungen ermittelt und können im Praxisbetrieb abweichen.
 Es handelt sich bei den Angaben weder um Beschaffenheits- noch um Haltbarkeitsgarantien.
 All technical data have been measured in a laboratory environment and can be different during practical usage of the product. Any product information is for descriptive usage only and not legally binding; particularly the information does not constitute or provide any legal guarantees ("Beschaffenheitsgarantie" or "Haltbarkeitsgarantie").

Gewicht (errechnet) / Calc WT: 750 g		Zul. Abw./Tolerances:		Maßstab / Scale: 1:2		A3			
Prüfmaß / Testdimension		ISO 2768-m		DIN / ISO 13715		CUSTOMER DRAWING			
Teileindex / Partindexnumber:									
Bagatelle change:						Crimpzange komplett crimping tool complete			
		Gez. 20.07.2016							
		Drawn PWOELFFLE							
		Status Released							
		Gepr. 13.01.2021				M TB 0400 146			
		Checked MBERTSCH							
						Blatt / Sheet 1			
02 202100013 12.01.2021 PWÖLF						1 Bl.			
01 201600001 20.07.2016 PWÖLF									
Index Änderung / Description		Datum / Date		Name		Ers. f. / Replacement for:			

FAI2021-000077
NXM-V02