

THIS DRAWING IS SUPPLIED FOR INFORMATION ONLY. DESIGN FEATURES, SPECIFICATIONS AND PERFORMANCE DATA SHOWN HEREON ARE THE PROPERTY OF THE AMPHENOL CORPORATION. NO RIGHTS OF REPRODUCTION ARE IMPLIED. ALL DIMENSIONS ARE SUBJECT TO NORMAL MANUFACTURING VARIATIONS.

CUSTOMER DRAWING

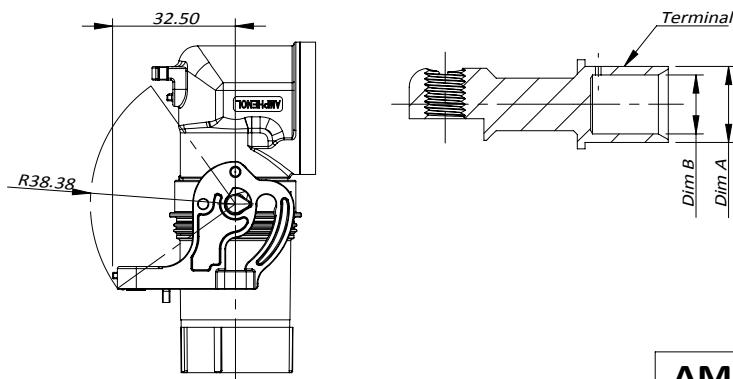
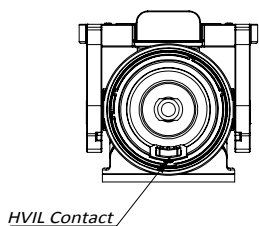
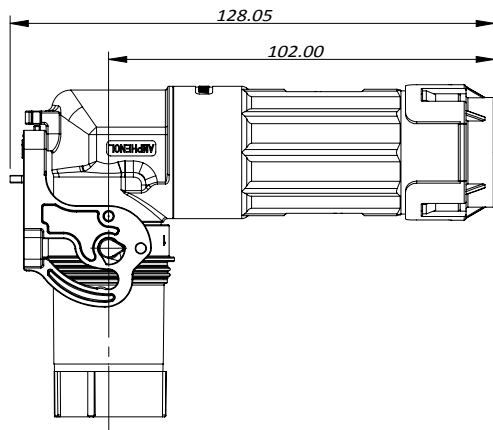
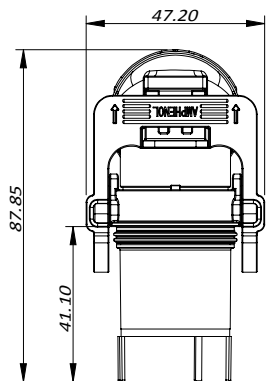
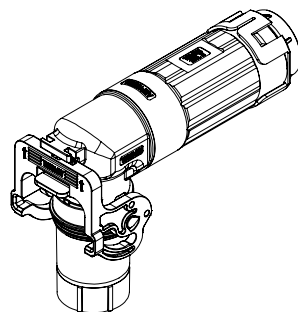

REVISIONS					
REV#	ECN#	REVISION ACTION	REV.BY:	APPR.BY:	DATE
A	--	INITIAL RELEASE	Jack	James	03/31/2020
B	--	增加表格信息	Star	James	10/29/2020

订购信息 Ordering Information

PL28 X - 50 1 - 95 - 2 - 5

Key and Color	HVIL	Cable size:	Cable Type:
"X", Orange	"0", NO HVIL	"70"=70mm ²	"-5", Huber+Suohner
"Y", Black	"1", With HVIL	"95"=95mm ²	
"U", Yellow		"120"=120mm ²	
"V", Green			
"W", Red			
"T", Blue			

规格参数(Spec.):

- 工作温度 Operating temperature: -40°C ~ +125°C.
- 带高压互锁 Electrical interlock (HVIL).
- 额定电流 Current rating:
Power: 70mm², 250A; 95mm², 300A; 120mm², 400A; HVIL: 5A.
- 额定电压 Operating voltage:
Power: 1000 VDC; Signal: 60 VDC.
- 耐电压 Dielectric withstanding voltage:
A. 与插座对插后, Pin与铁壳之间
When mated, between pin and metal shell: 5000 VDC.
B. 与插座对插后, Pin与HVIL之间
When mated, between pin and HVIL: 5000 VDC.
C. 与插座对插后, HVIL与铁壳之间
When mated, between HVIL and metal shell: 500 VDC.
D. 与插座对插前, 两个HVIL端子之间耐压
Before mating, between two HVIL terminals: 500 VDC.
- 防护等级 Protection class: Mated-IP6k9k & IP67, unmated-IP2X.
- 电磁屏蔽 360° full Shielding.
- 机械寿命 Mating cycle: 100 Min.
- 带CPA的摇杆系统 Latch system with CPA.
- 绝缘材料满足UL94 V-0 Inner insulation material satisfy UL94V-0.
- 镀锌/镍合金, 符合RoHS, 满足500H中性盐雾实验
Gray Zinc/Nickel(ZnNi) Plating. RoHS compliant, Rated at 500hours salt spray.

Standard Part List:

Model No.	H+S Part No.	Dia. Primary Insulation(mm)	Dia. of Screen max. (mm)	Overall-Dia. Nominal(mm)	Outside-Dia. of terminal(mm): "A"	Inside-Dia. of terminal(mm): "B"
PL28(X)-50X-70-2-5	84100298	13.7±0.3	14.6	17.0±0.3	16.7±0.3	12.2±0.3
PL28(X)-50X-95-2-5	84100299	16.2±0.3	17.3	19.9±0.4	17.9±0.3	13.9±0.3
PL28(X)-50X-120-2-5	84103410	18.0±0.3	19.1	22.6±0.4	20.1±0.3	15.6±0.3

	Amphenol Technical Products International Asia.					PART NAME: PL14mm G2 Right Angle Plug
	第三角投影 THIRD ANGLE PROJECTION	页面 SHEET	幅面 SIZE	版次 REV.	比例 SCALE	
	⊕	1 OF 2	A4	B		
	签名 SIGNATURE	日期 DATE	UNLESS OTHERWISE SPECIFIED			DWG NO: PL28X-50X-XX-2-5
制图 DRAWN	Star	10/29/2020	1) All dimensions are in metric(mm).			
审核 CHECKED			2) Tolerances are as follows: 1.PL DEC ± 1.00 2.PL DEC ± 0.50 3.PL DEC ± 0.20			
批准 APPROVAL				Angles ±1°	CUST PART # 	CUST REV.

