

MOUNTING PLATE SIZE

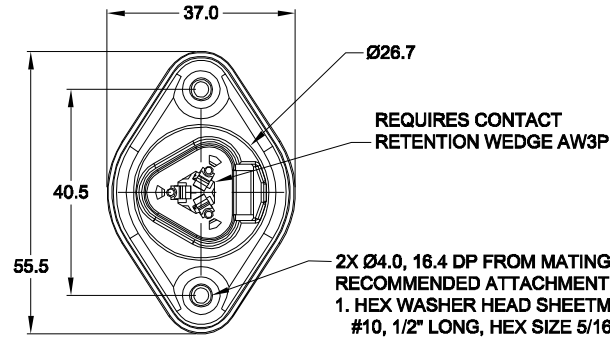

- 2X Ø4.0, 16.4 DP FROM MATING SURFACE
 RECOMMENDED ATTACHMENT OPTIONS:
 1. HEX WASHER HEAD SHEETMETAL SCREW, #10, 1/2" LONG, HEX SIZE 5/16".
 2. SELF THREAD SCREW FOR PLASTIC SUCH AS ST 4.8

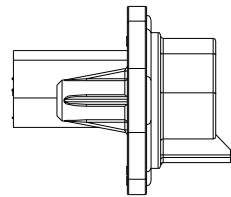
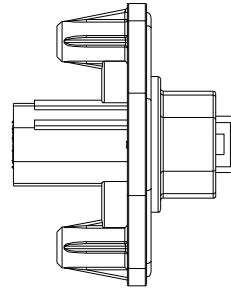
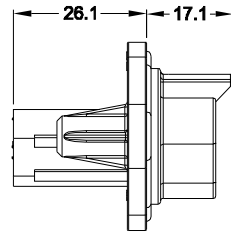
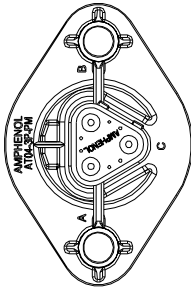
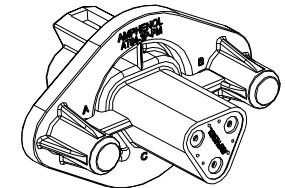
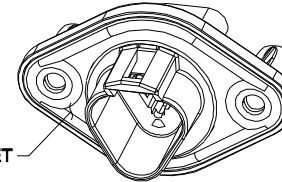

NOTES: UNLESS OTHERWISE SPECIFIED

1. MATERIAL:
 HOUSING: THERMOPLASTIC, COLOR: BLACK
 SEAL: SILICONE RUBBER
2. MODIFICATIONS: FLANGE, GASKET
3. SPECIFICATIONS:
 - 3.1 CURRENT RATING: 13 AMPS
 - 3.2 OPERATING TEMPERATURE: -55°C TO +125°C
 - 3.3 DIELECTRIC WITHSTANDING VOLTAGE: LESS THAN 2 MILLIAMPS CURRENT LEAKAGE @ 1500 VOLTS AC.
 - 3.4 INSULATION RESISTANCE: 1000 MEGOHMS MIN @ 25°C.
 - 3.5 MOISTURE RESISTANCE: IP67 (MATED CONDITION)
 - 3.6 MATING CYCLE DURABILITY: 100 CYCLES
 - 3.7 RoHS COMPLIANT
4. MATING PART: AT06-3S* PLUG (* = MODIFICATIONS)
5. ALL DIMENSIONS ARE FOR REFERENCE USE ONLY.

6 CONTACT SIZE AND REAR SEAL WIRE RANGE:

CONTACT SIZE	MIN. INSUL O.D.	MAX. INSUL O.D.	TYPICAL WIRE RANGE
16	2.24 mm (.088 in)	3.68 mm (.145 in)	14 - 20 AWG

REVISIONS					
REV	ECO	DESCRIPTION	DATE	BY	APPR
A1	-	RELEASE	30APR15	JAH	-
A2	-	REVISED GASKET SEAL	08SEP15	JAH	-
A3	-	UPDATE APPEARANCE	12APR16	JARRY	TOMMY

AT04-3P-PM11		DESCRIPTION		ITEM
QUANTITY	PART NUMBER	MATERIALS LIST		
UNLESS OTHERWISE SPECIFIED				
1) All dimensions are in metric(mm).				
2) Tolerances are as follows:				
1 PL DEC ±0.30 Fractions ±1/64				
2 PL DEC ±0.16 Angles ±1°				
3) Note reference =				
MATERIAL SPECIFICATIONS:		CUSTOMER:		
PROCESS SPECIFICATIONS:		THIS DRAWING IS SUPPLIED FOR INFORMATION ONLY. DESIGN FEATURES, SPECIFICATIONS AND PERFORMANCE DATA SHOWN HEREON ARE THE PROPERTY OF THE AMPHENOL CORPORATION. NO RIGHTS OF REPRODUCTION ARE IMPLIED. ALL DIMENSIONS ARE SUBJECT TO NORMAL MANUFACTURING VARIATIONS.		
NEXT ABBY:		SCALE: NONE		
SIGNATURES		DATE		
DRAWN: J.HEAD		30APR15		
CHECKED:				
ENGINEER:				
APPROVAL:				
Sine Systems - www.amphenol-sine.com		44724 Morley Drive		
Clinton Township, MI 48036		RECEPTACLE, 3 PIN, AT SERIES, W/FLANGE, GASKET		
SIZE	TYPE	DWG NO:	REVISION	
B	C-	AT04-3P-PM11	A3	
SHEET 1 OF 1				

TITLE: RECEPTACLE, 3 PIN, AT SERIES, W/FLANGE, GASKET
 DWG NO: AT04-3P-PM11
 REV: A3
 SH: 1
 OF: 1